

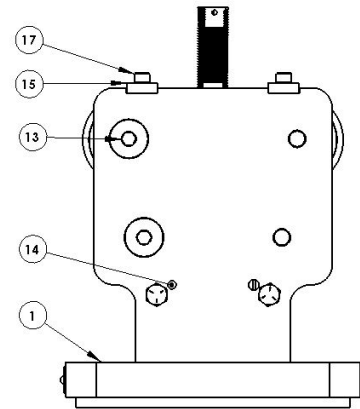

# Pressure Relief Valve PC280.5HS

ATTRIBUTES	
Set Pressure (psig)	280.5
Orifice Diameter (in)	2.56
Flow Area (sq. in)	5.14
Weight (lbs.)	43
Flow Rate @ 308.5 psig	23,396 SCFM
Height (in)	10.22
Flange Thickness (in)	0.88
Number of Bolt Holes	4
Bolt Hole Size (in)	0.94
Bolt Circle (in)	8.00
Interface Options	Tongue & Groove
Number of Springs	53

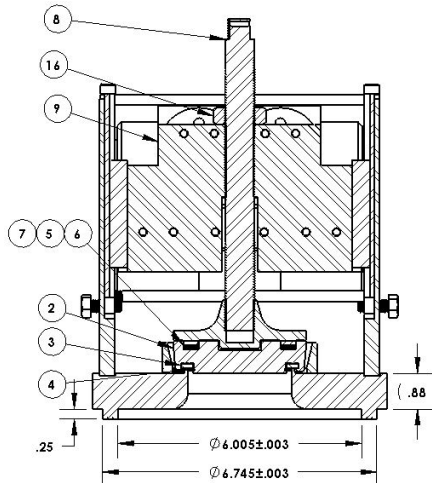

ITEM NO.	QTY.	DESCRIPTION	MATERIAL
1	1	BODY ASSEMBLY	STAINLESS STEEL
2	1	SEALING DISC	STAINLESS STEEL
3	1	SEAL*	ELASTOMER
4	1	SPIROLOX RING	STAINLESS STEEL
5	1	NEEDLE BEARING	CARBON STEEL
6	1	THRUST WASHER	CARBON STEEL
7	1	THRUST WASHER	CARBON STEEL
8	1	ADJUSTMENT SCREW ASSEMBLY	STAINLESS STEEL
9	1	SPRING BLOCK ASSEMBLY	STAINLESS STEEL
10	1	SPRING DRUM ASSEMBLY	STAINLESS STEEL
11	1	SPRING DRUM ASSEMBLY	STAINLESS STEEL
12	2	SPRING DRUM ASSEMBLY	STAINLESS STEEL
13	4	DRUM BOLT	ALLOY STEEL
14	2	LIFT STOP	STAINLESS STEEL
15	2	TOP BAR	STAINLESS STEEL
16	1	JAM NUT	STAINLESS STEEL
17	4	SOCKET HEAD CAP SCREW	ALLOY STEEL
18	1	COVER ASSEMBLY	CARBON STEEL
19	4	HEX BOLT	CARBON STEEL
20	2	NAMEPLATE RIVET	STAINLESS STEEL
21	1	NAMEPLATE	ALUMINUM

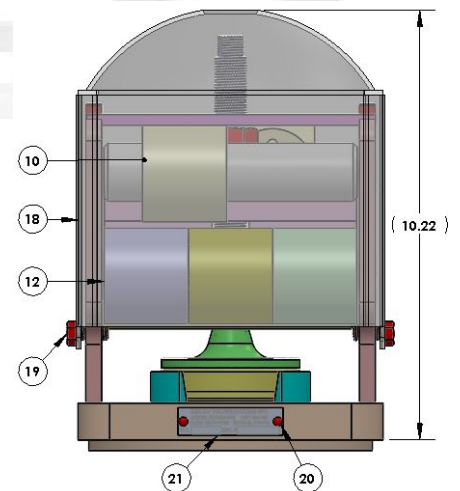
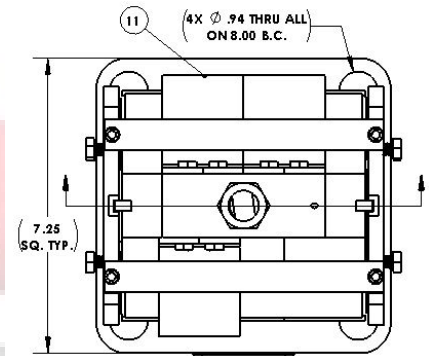

AAR Approval Number: PRD172102  
 Patent Number: US 9,568,146  
 Seal material composition based on specification  
 Other Sealing options available  
 Note: Mounting flange gasket not supplied  
 \*Alternate Materials Available